

Dual Thermal IP Camera

HI8060-MW

HI1612-MW

User Manual Ver 1.0



SAFTY WARNING AND CAUTION

TO REDUCE THE RISK OF ELECTRICAL SHOCK, DO NOT OPEN COVERS.
NO USER SERVICEABLE PARTS INSIDE. REFER SERVICING TO QUALIFIED SERVICE PERSONNEL.

Please be aware of the following precautions before installing the Camera.

- Avoid any place with moisture, dust, or soot.
- Avoid any place with direct sunlight or heating appliances.
- Keep the product away from electric shock or magnetic substances.
- Avoid high or low temperature.
- (Recommended operation temperature is between 0°C ~ 40°C)
- Do not place any conductive material through the ventilation.
- Turn off the system before installation.
- Ensure enough space for cable connections.
- Place the system on a solid surface with sufficient air ventilation
- Avoid any surface that vibrates.
- Do not disassemble the product without assistance from the manufacturer.
- Do not place any heavy object on the system.

The following are warning and caution statements for the safety of the users and for the prevention of any property damage. Please read below thoroughly.

Warning and Caution signs

Warning

If you are not aware of this warning,
you may be injured or be killed



Caution

If you are not aware of this warning, you may be
injured or cause property loss.



Warning

- Turn off the system before installing the system. Do not plug in several electric devices to the same outlet. This may cause heating, fire, or electric shock.
- Prevent power cable from being severely bent or pressed by a heavy object.

This may cause fire.

- Do not place any liquid container on the system, such as water, coffee, or beverage.

If liquid is poured onto the system, it can cause a system breakdown or cause fire.

- Clean the dust around the system on regular basis. When cleaning the system, always use dry cloth. Do not use wet cloth or other organic solvents.

This may damage the surface of the system and can cause system breakdown or electric shock.

- When pulling the power cable from the plug, do so gently. Do not touch the plug with wet hands and avoid using the plug if the holes on the outlet are too loose.

This may cause fire or electric shock.

- Avoid any place with moisture, dust, or soot.

This can cause fire or electric shock.

- Do not attempt to disassemble, repair, or modify, the system on your own.

It is extremely dangerous due to high voltage running through the system.

This may cause fire, electric shock, or serious injuries.

- Check for any danger signs such as moist floor, loosened or damaged power cable, or unstable surface. If you encounter any problems, ask for assistance from your dealer.

This may cause fire or electric shock

- Install the system in a cool place without direct sunlight and always maintain room temperature. Avoid candle light and heat-generating devices such as heater.

Keep the system away from places where many people pass. This may cause fire.

- Install the system on a plain surface with sufficient air ventilation.

Do not place the system on elevated surface.

This may cause system breakdown or serious injuries.



Caution

- Do not install the system in a place with high magnetic, electric wave, or wireless devices such as radio or TV.

- Install the system in a place with appropriate moisture and temperature level

Avoid installing the system with high (over 40°C) or low (under 0°C) temperature.

- Prevent any substances from being inserted into the system.

This may cause system breakdown.

- Do not place any heavy object on the system.

This may cause system breakdown.

- The system can be damaged from a strong impact or vibration.

Avoid throwing objects within the vicinity of the system.

- Avoid direct sunlight or any heating appliances.

- The outlet must be placed on the ground.

- If there is strange sound or smell, unplug the power cable immediately and contact the service center.

This may cause fire or electric shock.

- It is recommended to use AVR (Automatic Voltage Regulator) for stable power supply.

- In order to maintain stable system performance, have your system checked regularly by the service center.

- The manufacturer is not held responsible for system breakdown caused by mishandling.

- It is recommended to coil the core-ferrite around the connector of the system to avoid electromagnetic Interference.

CONTENTS

1. INTRODUCTION	- 5 -
1) FEATURES.....	- 5 -
2) SPECIFICATIONS	- 6 -
2. INSTALLATION	- 7 -
1) CABLE CONNECTION	- 7 -
2) NETWORK CONNECTION (LAN : LOCAL AREA NETWORK)	- 7 -
3) CHECK COMPUTER SETTING	- 8 -
4) CAMERA SETTING WEB PAGE	- 9 -
5) REMOTE ACCESS TO THE CAMERA	- 10 -
3. System Operation (Live Mode)	- 11 -
1) ACCESS TO LIVE MODE	- 11 -
2) LIVE MODE MENU	- 12 -
3) LIVE VIDEO MODE.....	- 14 -
4) LIVE MODE DISPLAY	- 15 -
4. System Operation (Setup Mode)	- 16 -
1) ENTERING SETUP MODE	- 16 -
2) MENU TREE	- 17 -
3) GENERAL.....	- 18 -
4) VIDEO	- 19 -
5) NETWORK	- 26 -
6) EVENT	- 26 -
7) SYSTEM.....	- 28 -
5. Troubleshooting Guide	- 29 -
1) HOW TO TROUBLESHOOT	- 29 -

THERMAL NETWORK CAMERA

1. INTRODUCTION

1) FEATURES

(1) DUAL SENSOR thermal ip camera

A. Visual Image Sensor

A) Sony Diagonal 6.15mm CMOS Progressive Scan / 3096(H) X 2202(V) : 6.82M Pixel

B. Thermal Image Sensor

A) Uncooled VOx microbolometer LWIR(Longwave infrared)

B) Thermal Resolution: [HI8060-MW] 80(H) X 60(V) / : [HI1612-MW] 160(H) X 120(V)

C) HI8060-MW: fov : 51° HFOV, 63.5° diagonal (f/1.1 silicon doublet)

HI1612-MW: fov : 56° HFOV, 71° diagonal (f/1.1 silicon doublet)

D) spectral range: 8 ~ 14μm

E) shutter integrated

(2) display mode

A. Visual / Thermal (Color/BW) / Overlay

Visual

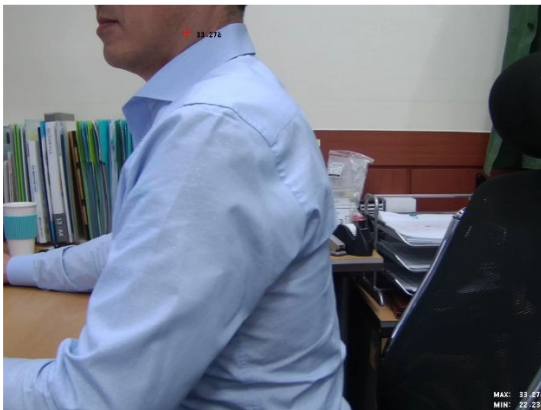

Thermal (BW)



Thermal (Color)

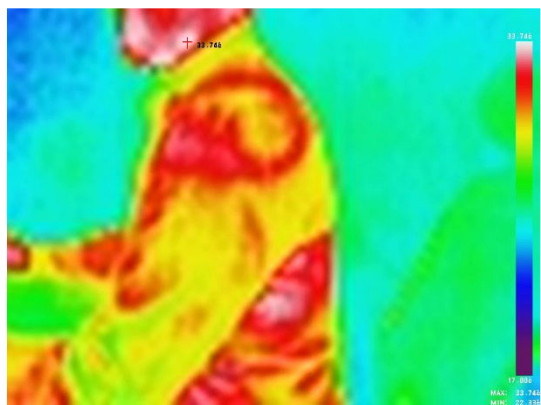

Overlay1

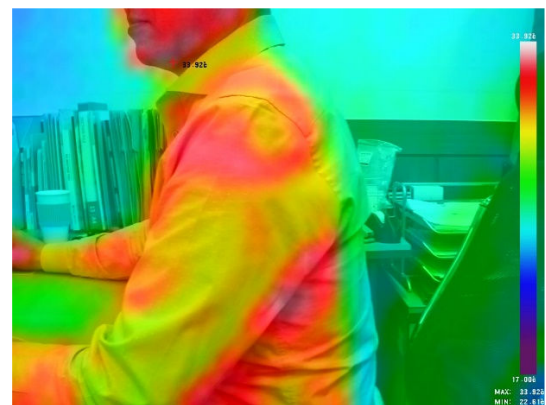

(3) ONVIF compatible

A. compatible with third party NVR and VMS

2) Specifications

Features		Description
Thermal	IR Sensor Framerate	< 9 Hz
	IR Sensor Resolution	HI8060-MW: 80(H) × 60(V) Pixel / HI1612-MW: 160(H) X 120(V)
	Spectral Range	8 to 14μm LWIR
	FOV	8060-MW: 51° HFOV, 63.5° diagonal (f/1.1 silicon doublet Lens) 1612-MW: 56° HFOV, 71° diagonal (f/1.1 silicon doublet lens)
	NETD	<50 mK (0.050° C)
	Object Temperature Range	HI8060-MW: -10 °C ~ 150 °C HI1612-MW: Low Gain Mode: -10 °C ~ 140 °C High Gain Mode: -10 °C ~ 450 °C
CMOS	CMOS	Sony Diagonal 6.15mm CMOS Progressive Scan
	Effective Pixels	3096(H) X 2202(V) : 6.82M Pixel
	Frame Rate	30 fps
	Resized Resolution	[HI8060-MW] Visual Mode Only: 2592X1944, 2048X1536, 1600X1200 All Modes: 1920X1080, 1280X720, 1024X768, 640X480 [HI1612-MW] Visual Mode Only: 2592X1944, 2048X1536, 1600X1200 All Modes: 1280X720, 1024X768, 640X480
Network	Ethernet	RJ-45 (10/100BASE-T)
	Network	DHCP / IP v4
	Protocol	ONVIF, TCP/IP, UDP/IP, RTP(UDP), RTP(TCP), RTSP, HTTP, DHCP
	Maximum Users	8 (RTSP Streaming)
	Language	Korean, English, Japanese, Chinese, Turkish
	Web Viewer	OS : Windows XP or higher Browser: IE 7.0 or higher
Others	Alarm Out	1 Port (Dry contact, relay out)
	Operating Temperature	0°C ~ +50°C (32°F ~ +122°F) / 20% ~ 80% RH
	Power	PoE (IEEE 802.3.af) / DC 12V
	Power Consumption	3.9W
	Dimension (wxhxd)	80x113x33.1(mm), 80x113x41mm Foot(Mount Bracket)
	Weight	320g

2. INSTALLATION

1) Cable Connection

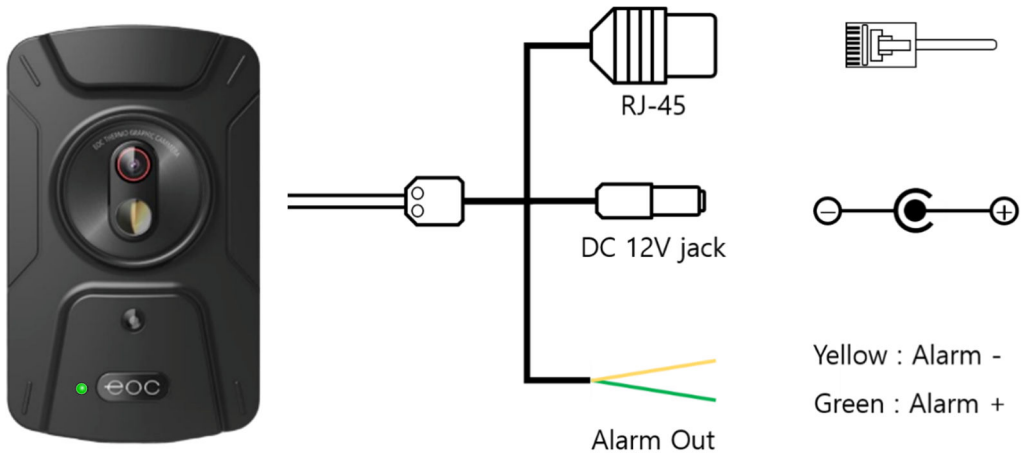

Name	Function
RJ-45 Connector	Connected to PoE or Ethernet cable.
DC 12V Jack	Connected to Power Cable
Alarm out	Connected to Alarm-out Device. (Siren, alarm light and etc.)

2) Network Connection (LAN : Local Area Network)

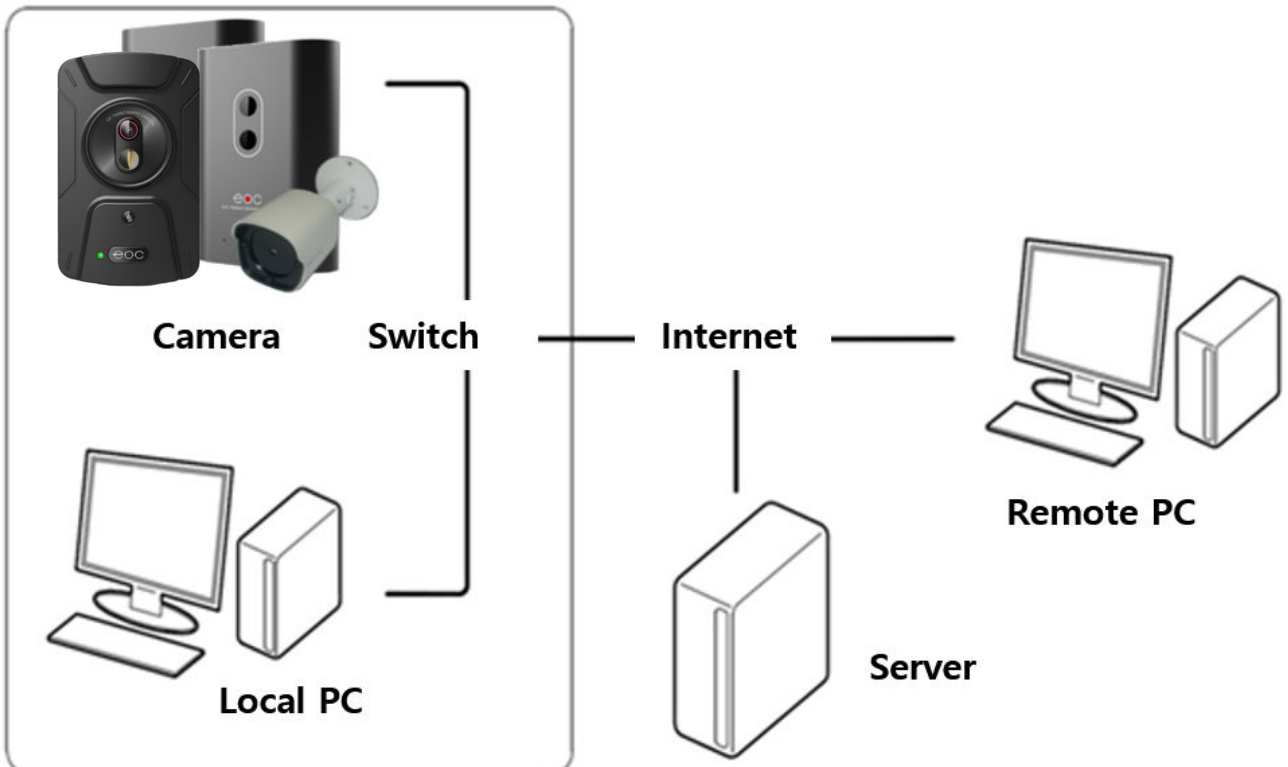

3) Check Computer Setting



4) Camera Setting Web Page

1	Check if the camera is on.
---	----------------------------



2	Run Internet Explorer.
In case of 'Window 7 or higher', run as a 'Administrator Authorization'.	



4	Enter ID and Password. Default [ID: admin], [PW: 1111]
 <p>Default ID / PW admin / 1111</p>	



3	Enter the IP address on address bar.
Default address is set to [DHCP]. Use the IP Search Tool "IP Installer," to find the camera IP assigned for your installation network environment. You can download "IP Installer" from our website; http://eoctech.net/bbs/board.php?bo_table=download&wr_id=1	

5) Remote Access to the Camera

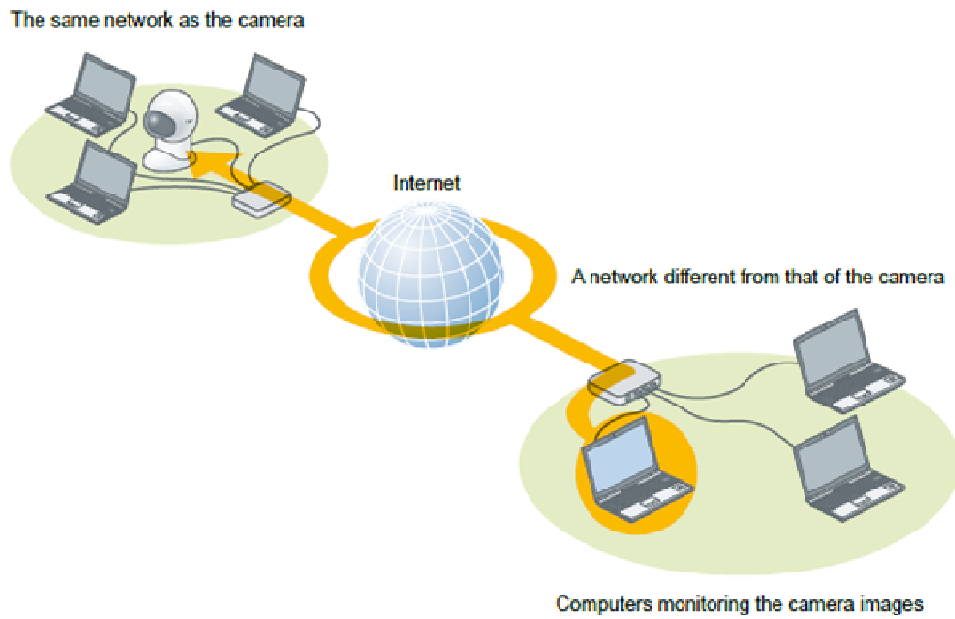

(1) Some settings of Router should be changed in order to check the live view or change the settings of the camera that is connected at long distance. (ex. Address converting)

(2) Each manufactures has own way to set up. For more information, please refer to the instruction manual supplied to each router or contact the manufacturer of router.

3. System Operation (Live Mode)

1) Access to Live Mode

When you enter the camera's IP address in the Internet Address bar, the camera's settings page opens and pops up the login password confirmation window as shown below.

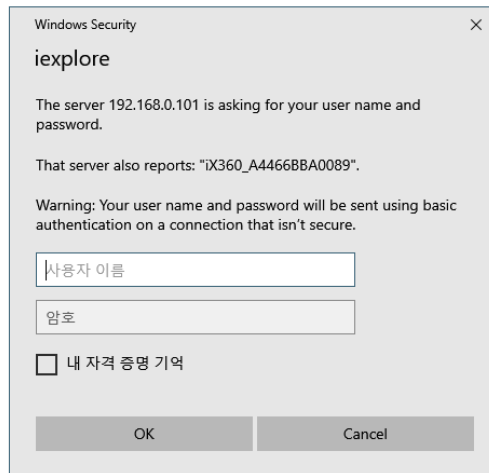

The default user ID and password are admin / 1111.

To protect your information, change your password after your first login (Warning pop-up window will continue).

Run Internet Explorer as administrator. There might be a limit on some menus.

Our thermal cameras only support Internet Explorer as web browser.

2) Live Mode Menu

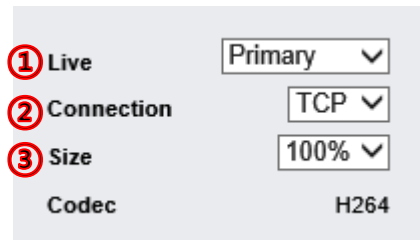

(1) Select Video Streaming:

- A. The camera supports dual streaming (Primary / Secondary)
- B. Each stream can be set to a different Mode.
i.e.) Primary: Visual / Secondary: Overlay

(2) Select Connection Protocol:

- A. Change the protocol to your network. (TCP / UDP)

(3) Adjust Screen Size:

- A. The screen size changes. (100% / 50% / 25%)

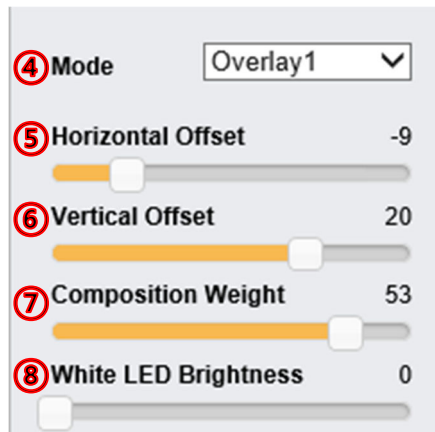

(4) Mode :

- A. Visual : CMOS general video surveillance mode
- B. Thermal (BW) : thermal black&white mode
- C. Thermal : thermal color mode
- D. Overlay1 : composite video mode 1 of visual and thermal video
Combining the color of the thermal image and the brightness of the visual image
A) Visual representation of temperature is based on the color bar selected.

(5) Horizontal Offset : Adjusting when there is discrepancy in positions between visual and thermal image. Move the visual image to the left or right based on the thermal image

(6) Vertical Offset : Adjusting when there is discrepancy in positions between visual and thermal image. Move the visual image up or down based on the thermal image

(7) Composition Weight: This option determines the degree of synthesis of visual and thermal videos on overlay mode.

(8) White LED Brightness: LED on the front of the camera can be turned on or off, and brightness can be

THERMAL NETWORK CAMERA

adjusted from 1 to 5 when turned on.

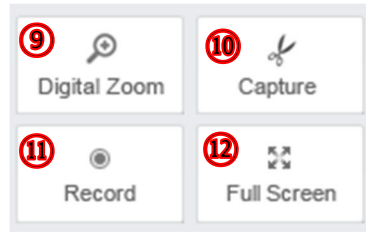

(9) Digital Zoom

- A. When the button is pressed, a reduced full window appears at the bottom right of the screen.
- B. Right-click in the zoom window and you'll see the Select Zoom Rate window.
- C. When you select a ratio, the entire screen is enlarged to match the ratio.
- D. When moving the square grid in the bottom zoom window, the entire screen is moved together.
- E. Enlarge screen up to 16x in digital zoom.

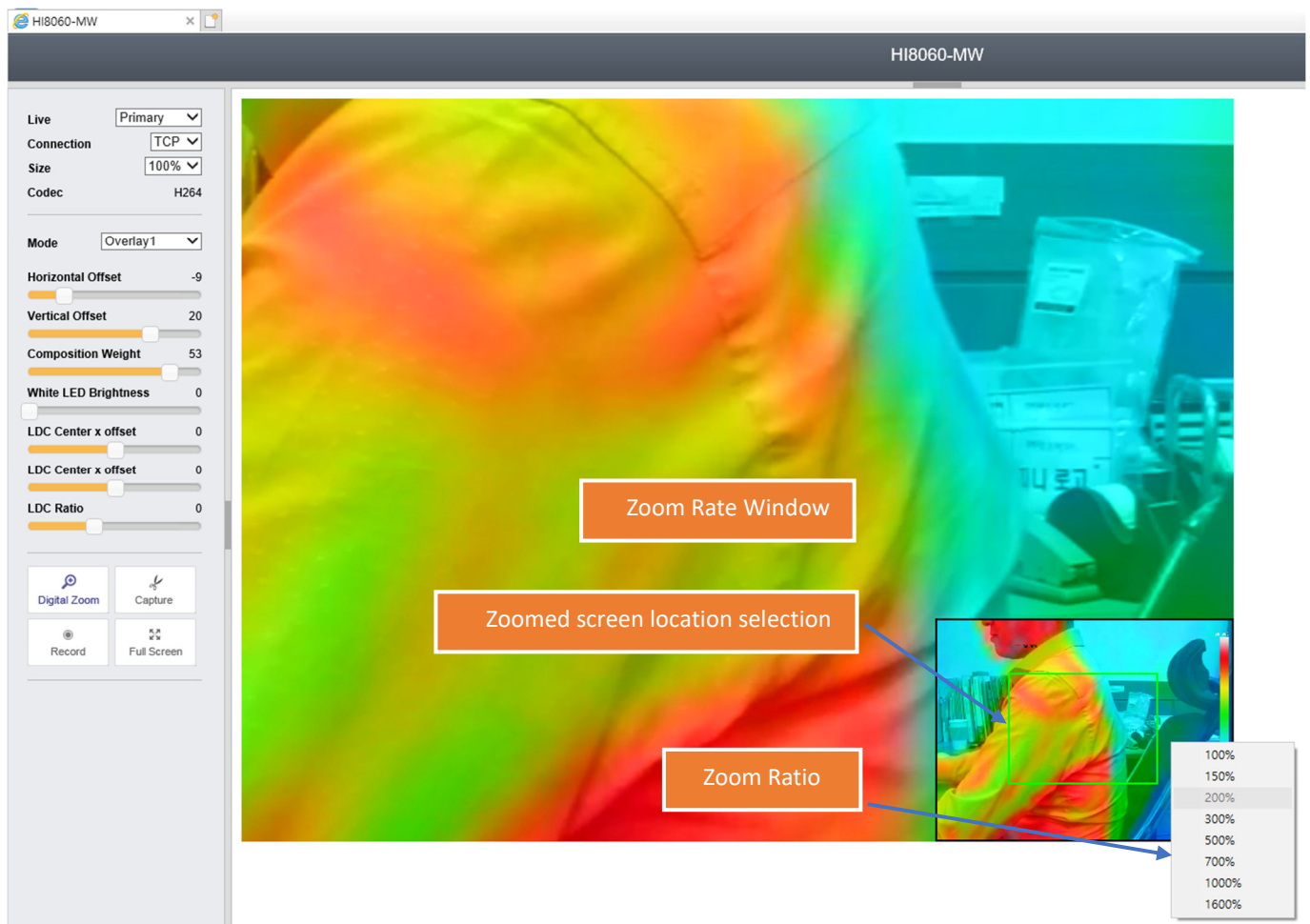

(10) Capture : The captured image is saved as JPEG.

- ※ The captured images are stored in C:\Users\USER\Documents.
- ※ To perform the capture function, IE must be run with administrator rights.

(11) Record : Live streaming is recorded as AVI.

- ※ The captured images are stored in C:\Users\USER\Documents.
- ※ To perform the capture function, IE must be run with administrator rights.

(12) Full Screen : Live video is shown in full screen. Press the 'ESC' key or double-click the mouse to return to the original screen.

3) Live Video Mode

① Visual



② Thermal(BW)



③ Thermal

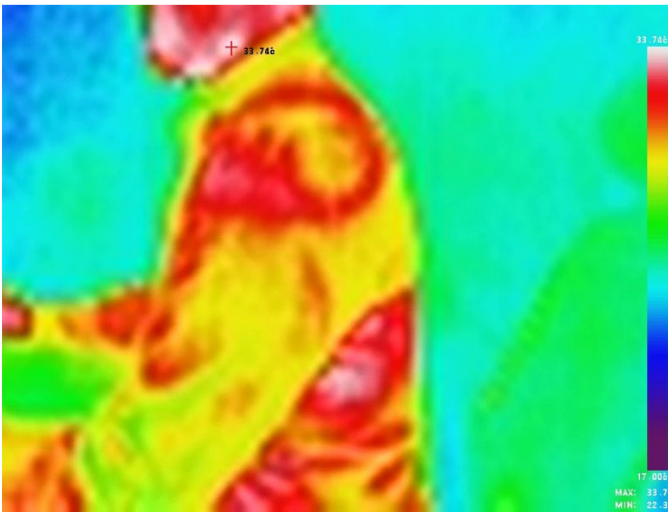

④ Overlay 1



4) Live Mode Display



(1) Maximum Temperature Point

(2) Point Measurement Temperature

- A. When you set the temperature point you want to measure on the screen, the temperature of the low point set at the bottom is displayed. (Up to 10 points: 0 to 9)
The temperature information is overlaid at the bottom of the screen and sent with the image in video streaming.

(3) Dynamic Range (Upper)

- A. Dynamic Range On
 - A) Displays the maximum temperature measured on the screen.
- B. Dynamic Range Off
 - A) Displays the temperature entered in Daynamic Range OFF (Upper) on [Live Screen Setup] menu.
 - B) Temperature above set value is displayed in maximum temperature color.
(ex. The top color on the color bar, white color on 'White Rainbow' color bar)

(4) Dynamic Range (Lower)

- A. Dynamic Range On
 - A) Displays the minimum temperature measured on the screen.
- B. Dynamic Range Off
 - A) Displays the temperature entered in Daynamic Range OFF (lower) on [Live Screen Setup] menu.
(A) Temperature BELOW set value is displayed in maximum temperature color.
(ex. The top color on the color bar, PURPLE color on 'White Rainbow' color bar)

(5) Maximum Temperature: Displays the highest temperature on the screen.

(6) Minimum Temperature: Displays the highest temperature on the screen.

4. System Operation (Setup Mode)

1) Entering Setup Mode

(1) Entering the camera's IP address in the Internet address window opens the camera's settings page and pops up the login password confirmation window.

(2) The default mode is Live mode and you can access Setup mode by pressing **SETUP** button as shown in the image below

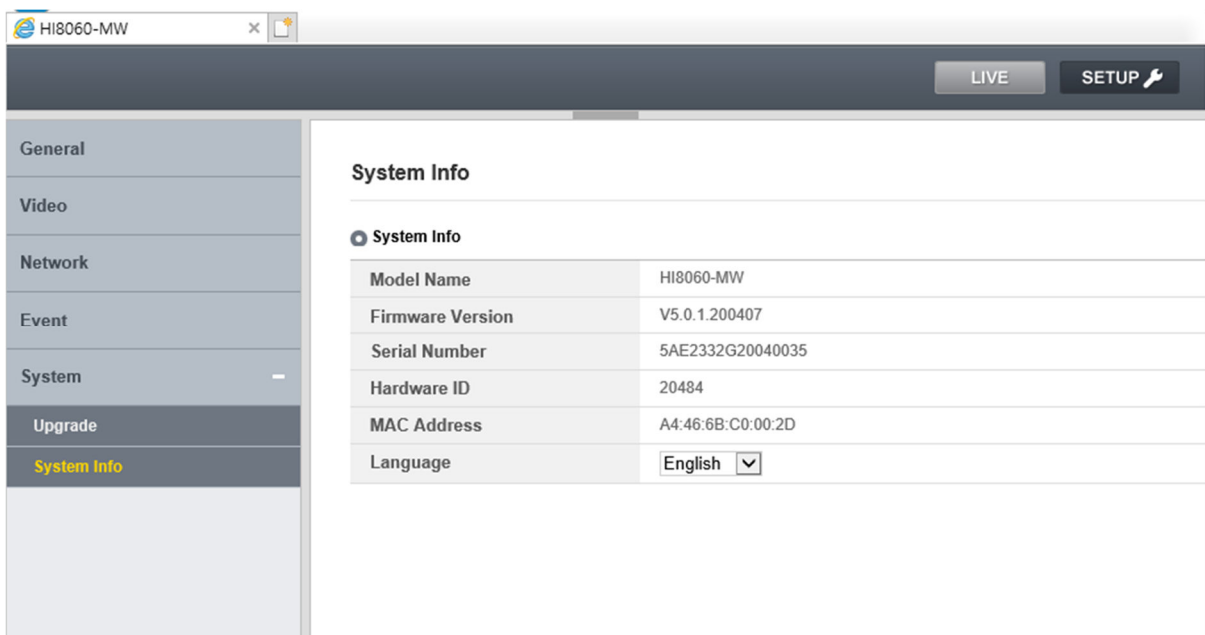
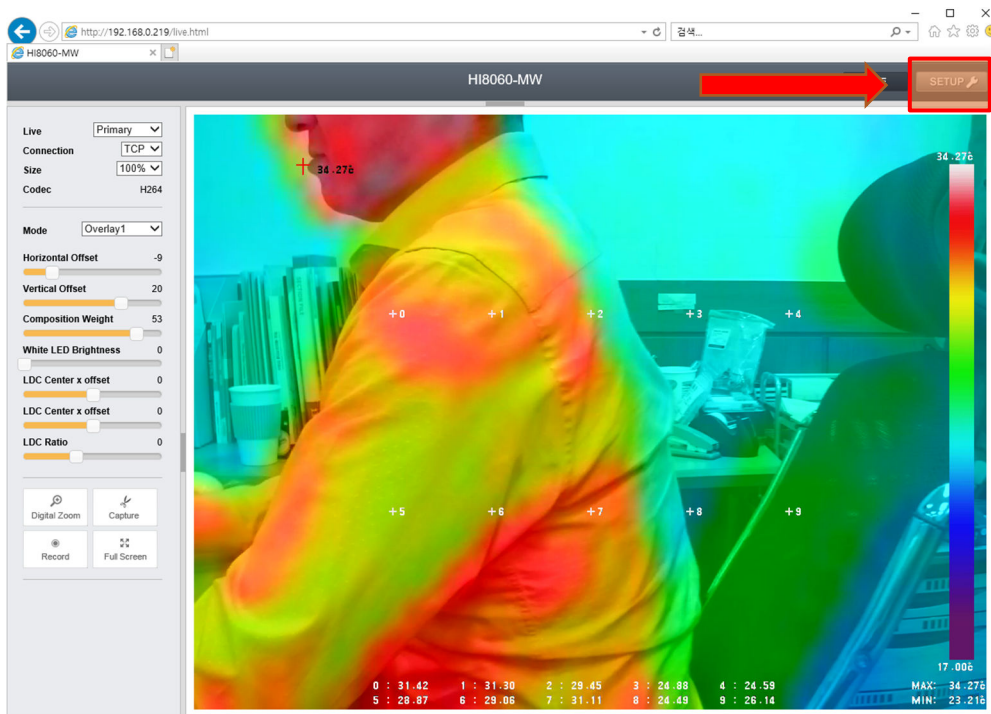

2) Menu Tree

Menu	Item	Description
General	Users	Add or delete users of the camera.
	Change Password	Change the password of the registered user.
	Date & Time	Setup time information and time zone.
Video	Thermal Parameter Setup	This is the value needed to calculate the temperature of the camera. (Please do not change the values. They are optimized before factory shipment.)
	Live Screen Setup	Set information and functions displayed on the screen.
	Measurement Point Setup	Set the desired temperature measurement position. (Up to 10 measurement points are available from 0 to 9)
	Video Stream Setup	Set up video values like video compression, GOP etc.
Network	TCP/IP Setup	Set up the camera's network configurations.
Event	Alarm Setup	Sets the default value of the alarm output.
	Event Server	This menu is for some users who operate event server.
System	Upgrade	Reset or update the camera's settings.
	System Info	Display the version and information of the camera.

3) General

(1) Users

Users

User ID	<input type="text"/>	User ID	Authority
Password	<input type="text"/>	<input type="radio"/> admin	Administrator
Confirm Password	<input type="text"/>	<input type="button" value="Delete"/>	
Authority	Operator <input type="button" value="v"/>		

A. Add or delete user accounts.

B. Authorization

A) Administrator

(A) Access all menus.

B) Operator

(A) Access all menus except 'Users' menu.

C) User

(A) Access only 'Video' Menu.

D) Guest

(A) View live video only.

(2) Change Password

Change Password

User ID	admin
Current Password	<input type="text"/>
New Password	<input type="text"/>
Confirm New Password	<input type="text"/>

A. Change the password of a registered user account.

(3) Date & Time

Date & Time

Time Information

Start Time	2000/01/05 12:18:49	Current Time	2000/01/05 21:53:59
------------	---------------------	--------------	---------------------

Time Mode

Time Zone	(GMT-12:00) International Date Line West <input type="button" value="v"/>
-----------	---

Synchronize with computer time Synchronize with NTP server Set Manually

A. Time Information

B. Time Mode

4) Video

(1) Thermal Parameter Setup

Parameter	Value	Range
R	979061.00000	170500.00, 0~1000000
B	2745.00000	1628.00, -16384~16383
F	-194.75500	0.00, -16384~16384
O	102.00000	7000.00, -16384~16383
Offset	0.00	0, -100~100
Twin	24.85	25.00, -100.00~370.00 (C)
Tatm	24.85	25.00, -100.00~370.00 (C)
Tbkg	24.85	25.00, -100.00~370.00 (C)
Trefl	24.85	25.00, -100.00~370.00 (C)
TauWin	1.000	1.000, 0.001~1.000
GammaWin	0.000	1.000, 0.001~1.000
TauAtm	1.000	1.000, 0.001~1.000
P1	1.00000	
P2	-0.00000	
T-Linear Mode	<input type="radio"/> ON <input checked="" type="radio"/> OFF	
Temperature Measurement	<input checked="" type="radio"/> ON <input type="radio"/> OFF	
Temperature Offset	0.0	(C)

1. R / B / F / O, Offset

- A) Thermal parameter value to calculate temperature from the values measured by thermal sensor.
- B) When there is a discrepancy between the actual temperature and measured one, adjust the deviation by entering compensation temperature on the offset.

2. Environmental Variables

- A) The environmental variables that affect the measured values obtained from the thermal sensor are quantified to increase the temperature accuracy.
- B) E : Emissivity of the measurement object (The skin of human body: 0.97 ~ 0.98)
- C) Twin : Temperature of the window / TauWin : Transmissivity of the window
- D) GammaWin : Reflection coefficient of Window
- E) Tbkg : Background temperature reflected by measurement object
- F) Tatm : Ambient temperature / TauAtm : Atmospheric temperature
- G) P1, P2 : The parameters calculating the environmental variables above according to the formula

3. T-Linear Mode

- A) OFF: Use factory default RBFO values
- B) ON: Variable temperature values according to FPA sensor temperature
 - High Gain Mode: Temperature measurement ranging -10 ~ 150
 - Low Gain Mode: Temperature measurement ranging from -10~410

TEMPERATURE MEASUREMENT

- A) NO: Operation of camera human body measurement mode (creates a human shape in the lower image)
- B) OFF: Camera industrial measurement mode operation

THERMAL NETWORK CAMERA

The menu must be maintained at the factory shipment value and if any other changes or modifications are needed, contact the supplier.

(2) Live Screen Setup

Live Screen Setup

Horizontal Offset	-9
Vertical Offset	20
Dynamic Range(Upper)	<input checked="" type="radio"/> ON <input type="radio"/> OFF Max 34 -100~370(C)
Dynamic Range(Lower)	<input type="radio"/> ON <input checked="" type="radio"/> OFF Min 17 -100~370(C)
Mode_T	<input type="radio"/> Kelvin <input checked="" type="radio"/> Celsius <input type="radio"/> Fahrenheit
Colorbar	WhiteRainbow ▾
Event Report	<input checked="" type="radio"/> ON <input type="radio"/> OFF
Event Max Temperature	50.00 -100~370 (C)
Relay Output	<input type="radio"/> ON <input checked="" type="radio"/> OFF
LED On	<input checked="" type="radio"/> Enable <input type="radio"/> Disable
OSD	<input checked="" type="radio"/> Enable <input type="radio"/> Disable

Apply Reset

Live Image

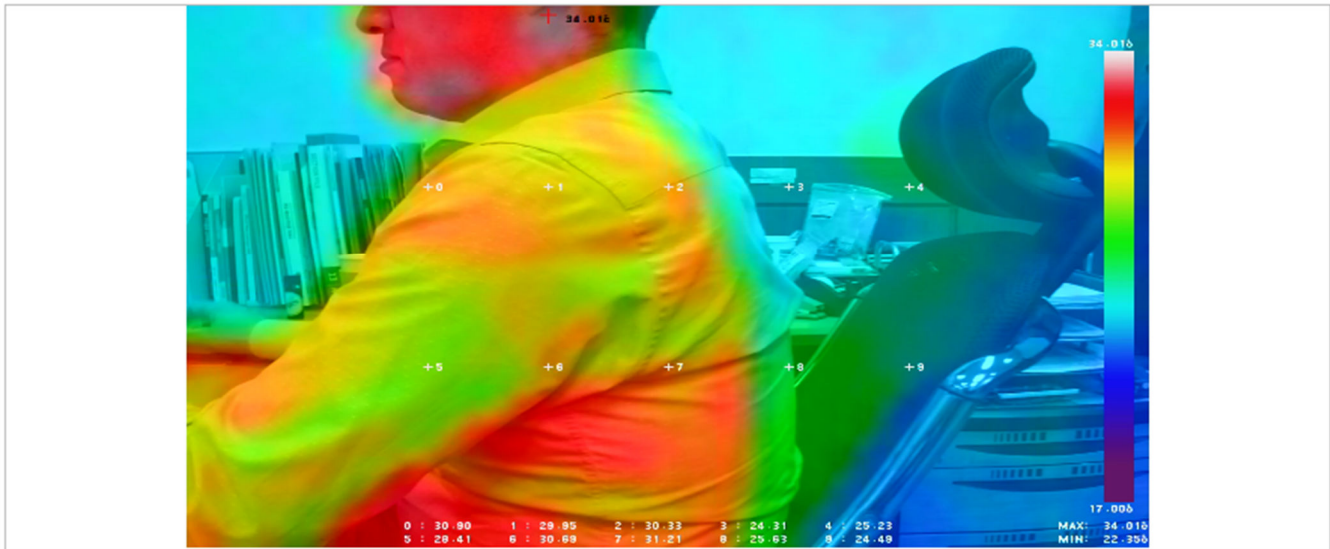

A. Horizontal / Vertical Image Sync

A) The horizontal / vertical adjustment values set on the “LIVE” mode are displayed.

B. Dynamic Range

A) Upper(ON), Lower(ON) : Display thermal image corresponding to both maximum and minimum temperature.

B) Upper(ON), Lower(OFF) : Display thermal image corresponding to the fixed minimum temperature.

C) Upper(OFF), Lower(ON) : Display thermal image corresponding to the fixed maximum temperature.

D) Upper(OFF), Lower(OFF) : Dynamic Range is not applied.

(A) When the upper value is set to less than the lower value, the color of the thermal image may not display normally.

THERMAL NETWORK CAMERA

C. Select Temperature Unit :

- A) Mode_T / Kelvin
- B) Mode_T / Celsius
- C) Mode_T / Fahrenheit

D. Colorbar:

- A) Select a color bar applied to Overlay Mode. 10 color bars are available.

E. Event Report

- A) Alarm is triggered when the maximum set temperature is detected.
- B) When [Event Report] is "ON", [Event Max Temperature] and [Relay Output] are activated to be entered.
- C) The triggered alarm is transmitted to a client (ef. NVR) in ONVIF motion detection protocol.

F. Event Max Temperature

- A) Set the temperature at which the alarm will be triggered. Alarm is triggered when a value above that temperature is detected.

G. Relay Output

- A) Activate the external output when an alarm is triggered.
- B) The alarm output settings are in accordance with [Alarm Setup] values in [Event] menu.

H. LED On

- A) Select "ON" if you want to turn on the LED on the front of the camera when temperature alarm event occurs.

I. OSD

- A) Enable/disable OSD display on the live screen.
- B) When disabled, temperature data display on the screen is not supported.

(3) Measurement Point Setup

Measurement Point Setup

10-point Temperature Display [(0,0) ~ (79, 59)]

No	X coordinate	Y coordinate	Activation
0	<input type="text" value="20"/>	<input type="text" value="20"/>	Enable <input type="checkbox"/>
1	<input type="text" value="30"/>	<input type="text" value="20"/>	Enable <input type="checkbox"/>
2	<input type="text" value="40"/>	<input type="text" value="20"/>	Enable <input type="checkbox"/>
3	<input type="text" value="50"/>	<input type="text" value="20"/>	Enable <input type="checkbox"/>
4	<input type="text" value="60"/>	<input type="text" value="20"/>	Enable <input type="checkbox"/>
5	<input type="text" value="20"/>	<input type="text" value="40"/>	Enable <input type="checkbox"/>
6	<input type="text" value="30"/>	<input type="text" value="40"/>	Enable <input type="checkbox"/>
7	<input type="text" value="40"/>	<input type="text" value="40"/>	Enable <input type="checkbox"/>
8	<input type="text" value="50"/>	<input type="text" value="40"/>	Enable <input type="checkbox"/>
9	<input type="text" value="60"/>	<input type="text" value="40"/>	Enable <input type="checkbox"/>

Live Image



A. X coordinates input:

A) Enter X coordinates of the point on the screen you want to measure temperature (←0 ~ →629)

B. Y coordinates output:

A) Enter Y coordinates of the point on the screen you want to measure temperature (↑0 ~ ↓471)

C. Enable/Disable temperature measurement point

A) Select 'Disable' when you don't use temperature measurement point.

B) Select 'Enable' when you use temperature measurement point.

C) Up to 10 measurement points available.

(4) Video Stream Setup

Video Stream Setup

Primary Stream

Video Codec	H.264	
Resolution	2592X1944	▼
Frame Rate	20	▼ fps
I-Frame Interval	20	▼
Quality	CBR ▼	
Bitrates	6144	(256 ~ 10240)

Secondary Stream

Enable	<input checked="" type="checkbox"/>	
Video Codec	H.264 ▼	
Resolution	640X480	▼
Frame Rate	30	▼ fps
I-Frame Interval	30	▼
Quality	CBR ▼	
Bitrates	2048	(256 ~ 4096)

Apply Reset

A. Video Codec

A) Set video codec to H.264 or MJPEG. (Primary stream is fixed to H.264)

B. Resolution

A) Select video resolution

(A) Primary Stream:

- HI8060-MW: 2592 X 1944, 2048 X 1036, 1600 X 1200 (Visual Only) / 1280 X 720, 1024 X 768, 640 X 480
- HI1612-MW: 2592 X 1944, 2048 X 1036, 1600 X 1200 (Visual Only) / 1920 X 1080, 1280 X 720, 1024 X 768, 640 X 480

(B) Secondary Stream

- HI8060-MW: 1280 X 720, 1024 X 768, 640 X 480
- HI1612-MW: 1920 X 1080, 1280 X 720, 1024 X 768, 640 X 480

C. Frame Rate

A) Set how many video frames are compressed per second. (1~30fps)

(A) The actual number of frames may be smaller depending on each network bandwidth limit setting.

(B) If the generated data cannot be transmitted on the network, it appears to be less than the set value.

D. I-Frame Interval

A) I frame interval sets the number of P frames between full frames.

(A) The I-frame interval for video can be set from 0 to 30.

(B) If set to 0, no I frame is made.

THERMAL NETWORK CAMERA

E. Quality

A) VBR(Variable BitRate)

(A) To minimize image quality loss, select VBR which enables video compression rate variable according to the movement of objectives and the complexity of the screen.

(B) 5 steps can be selected: Lowest-Low-Medium-High-Highest

(C) The compression bitrate varies greatly depending on the change or movement of the frame.

B) CBR(Constant BitRate)

(A) The video is compressed in fixed bitrate.

(B) Set it to 4Mbps or higher when there are many changes in image. Recommended if you have sufficient network bandwidth.

F. Bitrates

A) When you use CBR, enter fixed bitrate value.

G. Secondary Stream Enable

A) Check the checkbox if you want to use secondary streaming. (Dual Streaming)

5) Network

(1) TCP/IP Setting

● IP Address Configuration

<input type="radio"/> Obtain IP address via DHCP	
<input checked="" type="radio"/> Use the following IP address	
IP Address	<input type="text" value="192.168.0.101"/>
Subnet Mask	<input type="text" value="255.255.255.0"/>
Gateway	<input type="text" value="192.168.0.1"/>
Primary DNS Server	<input type="text" value="0.0.0.0"/>
Secondary DNS Server	<input type="text" value="0.0.0.0"/>

● HTTP & HTTPS

Web Server Port	<input type="text" value="80"/>	80, 1025~65535
-----------------	---------------------------------	----------------

● RTSP

RTSP Port	<input type="text" value="554"/>	554, 1025~65535
RTSP Login	<input checked="" type="radio"/> OFF <input type="radio"/> ON	

Apply

Reset

A. IP Address Configuration

A) Obtain IP address via DHCP

(A) DHCP server automatically assigns an IP to the camera.

B) Use the following IP address: Enter the network information below according to the network environment where the camera is installed.

(A) IP address

(B) Subnet Mask

(C) Gateway

(D) Primary DNS / Secondary DNS Server

B. HTTP & HTTPS

A) Web Server Port : The typical HTTP service port is 80.

(A) Select between 1025 and 65535 if you use other web server port..

C. RTSP

A) RTSP Port : Video streaming port

(A) RTSP (Real Time Streaming Protocol)

a. The media transfer specification between the server and the client. The default setting value is 554, and the setting is available between 1025 and 65635.

(B) RTSP port number must be different from Web port number.

B) RTSP Login

(A) Set the login check if an external device connects to the camera and requests video.

a. OFF : No ID and password check when other devices connect to the camera.

b. ON : Check ID and password when other devices connect to the camera.

6) Event

(1) Alarm Setup

THERMAL NETWORK CAMERA

Alarm Setup

● Sensor/Relay Setup

Relay	
Device Setup	N/O <input type="button" value="v"/>
Name	Relay

A. When using the alarm output, enter the default settings for the connected alarm-out device.

A) N/C : Normal Close

(A) The alarm remains closed until an event is triggered.

B) N/o : Normal Open

(A) The alarm remains open until an event is triggered.

(2) Event Server

● SKVMS Setup

SKVMS Server Address	0.0.0.0
Port	7001
User ID	admin
Password
Source	ThermalEvent
Caption	area1

A. This menu is for those who use a specific VMS server named SKVMS. Please skip this menu when you don't use SKVMS server. For more information, please contact your local supplier.

7) System

(1) Upgrade

Upgrade

Maintain Server

Restart

Restart Network camera.

Reset

Reset all parameters, except the IP parameters.

Factory Default

Reset all parameters to the original factory settings.

Firmware Upgrade

Upgrade the with the latest firmware

찾아보기...

Upload

A. Restart

A) Turn off and turn on the camera. All the settings are not changed.

B. Reset

A) All values except the current IP settings will be initialized.

C. Factory Default

A) All values are deleted including User Accounts.

B) The factory default for IP is set to DHCP.

D. Firmware Upgrade :

A) Press the Browse button to find the firmware to upgrade on your PC to find.

B) Press the Upload button to begin the upgrade.

C) When the upgrade is complete, the camera will turn off and on automatically.

D) **DO NOT TURN OFF THE CAMERA, DURING THE UPGRADE.**

(2) System Information

System Info

System Info

Model Name	HI8060-MW
Firmware Version	V5.0.1.200407
Serial Number	5AE2332G20040035
Hardware ID	20484
MAC Address	A4:46:6B:C0:00:2D
Language	English ▼

A. Camera information is displayed.

A) Model Name

B) Firmware version

C) Serial number

D) Hardware ID

E) MAC address

B. Menu Language Setup: Korean / English / Japanese / Chinese / Turkish

5. Troubleshooting Guide

1) How to troubleshoot

Issue	How to resolve
I can't connect the camera through web browser	<ul style="list-style-type: none">. Check <network> setting value of the camera is correctly input.. Check network cable is connected correctly.. In case of connecting through DHCP, you should make sure that the camera achieves the dynamic IP address properly.. In case of connecting through DDNS URL, you should make sure MAC Address is correctly input.. In case the camera is connected through router, you should make sure the port forwarding is correctly made.
While live monitoring with <Web viewer>, the connection is failed.	<ul style="list-style-type: none">. Check the camera setting or network setting is changed.. Check network connection is properly made.. In case the camera is connected through PPPoE, possibly it happens once the network status is unstable. So you can try another network connection.
Can't connect the camera through tab browser on Internet Explorer7.0	<ul style="list-style-type: none">. It might happen on tab connection, because cookie info is shared and possibly conflicted. So please escape to use tab browser and try to connect by new window.
Can't find the camera on IP installer program.	<ul style="list-style-type: none">. Remove firewall setting on the PC system, and then try again.
The image looks like two images are overlapping.	<ul style="list-style-type: none">. In case of connecting multiple cameras, check if the same multicast address is assigned to those cameras.
Can't set the video	<ul style="list-style-type: none">. In case of multi cast streaming network, the network requires the router, which supportive for multi cast streaming.
Can't get alarm out work	<ul style="list-style-type: none">. Check alarm out port setting is correctly made.. 'Secondary Stream' should be checked to activate.



=====

For further help and advice please contact Antrica on:

Email: support@antrica.com

Phone: +44 (0)1628 626098

www.antrica.com

Antrica (Division of Zilica Ltd)

Office : +44 (0)1628 626098

Address: Unit B1 Westacott Business Centre, Maidenhead , SL6 3RT , United Kingdom

=====