

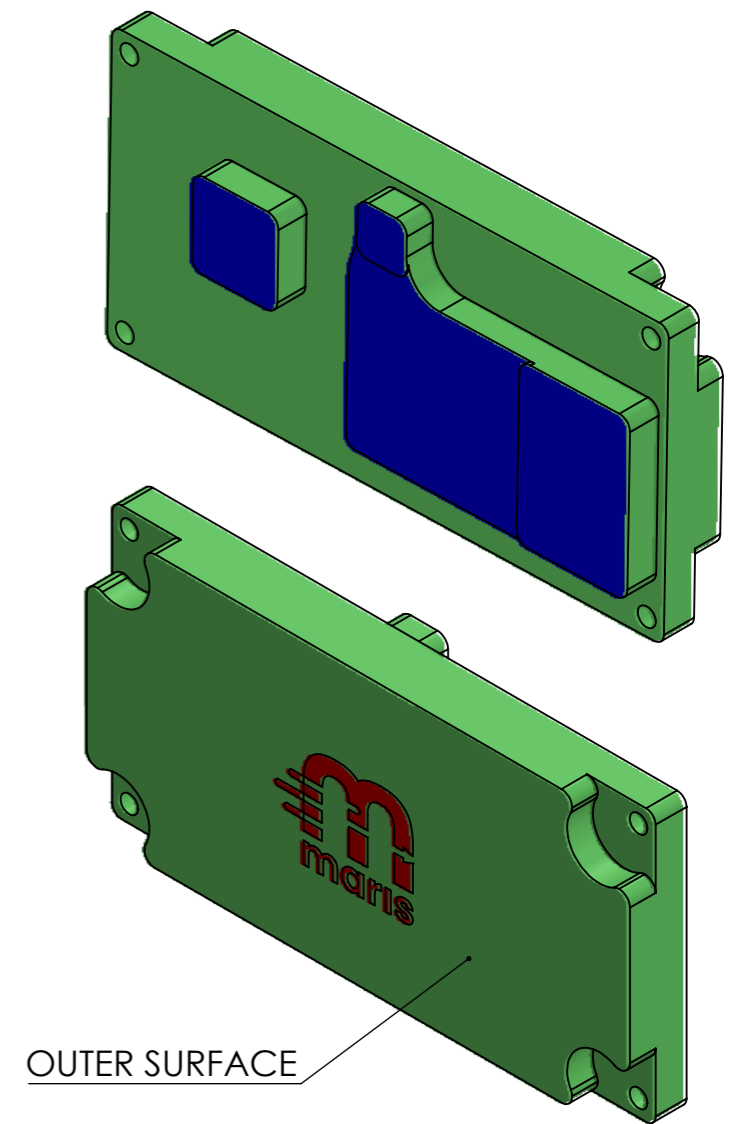

- This document is confidential.
 - All sole property of "FIT R&D".
 - Not to be copied or distributed.

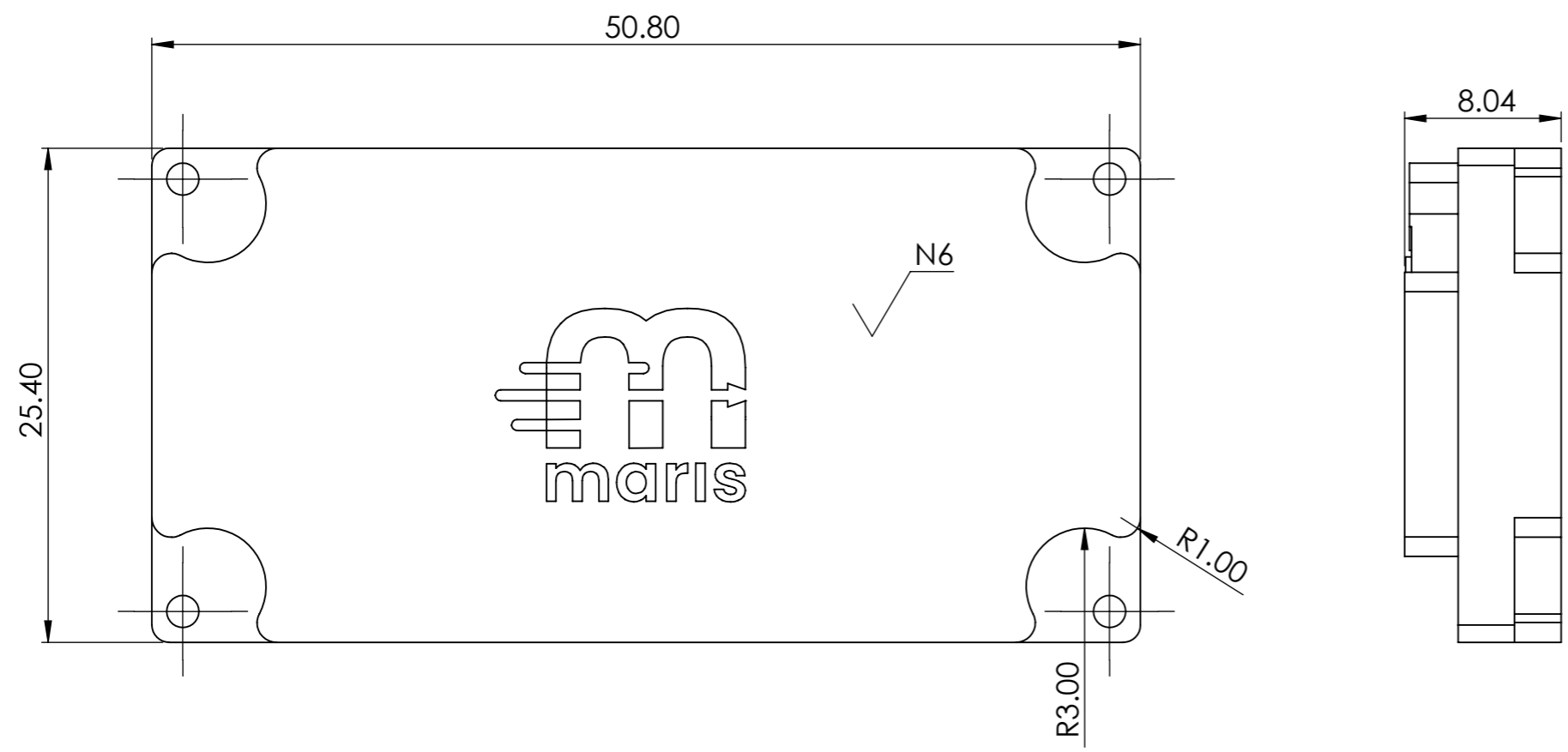

- NOTES:
- MATERIAL: AL.ALLOY 6061-T6 PER AMS QQ-250/11 OR AMS QQ-A-225/B.
 - The solid model file may be used for manufacturing and dimensional measurements purposes and shall be used for definition of dimensions not explicitly specified on the drawing. All notes and dimensional requirements specified on the drawing are obligatory.
 - FINISH:
 A - Remove machining marks (Outside only)
 B - SPI D3 - Ra.190-230 made by #24 aluminum oxide sandblasting. OUTSIDE SURFACE ONLY
 - COATING: Black Sulfuric Anodize per Mil-A-8625 Type II, Class 2
 - All Faces **Marked BLUE** - 0.05 FLATNESS Tolerance.
 - MARKED RED** - LOGO LASER ENGRAVING
 - Break all sharp edges R0.20 unless mentioned otherwise.
 - All threads must be masked before plating/anodizing.

MATERIAL:		Aluminum 6061 T6	
FINISH:		See Notes	
UNLESS OTHERWISE SPECIFIED TOL. ARE: X.XX ±0.05 X.X ±0.1 X ±0.2	ROUGHNESS: See Notes		
	ANGLES	±0.5°	
	DIMENSIONS ARE IN mm		
FIRST ANGLE PROJECTION		DRAWN	Elad.K
		DESIGN	12/10/2022
		CHECK	30/04/2023

 6 Kompert Street P - +972-(0)77-4418391 Tel-Aviv, ISRAEL F - +972-(0)77-4418392 www.fit-r-d.com			
DESCRIPTION:		Sheet1	
DWG NO:		338_1001_V03	
REV		A	
A3	SHEET # 1	OUT OF 4	SCALE: 3:1

- This document is confidential.
 - All sole property of "FIT R&D".
 - Not to be copied or distributed.

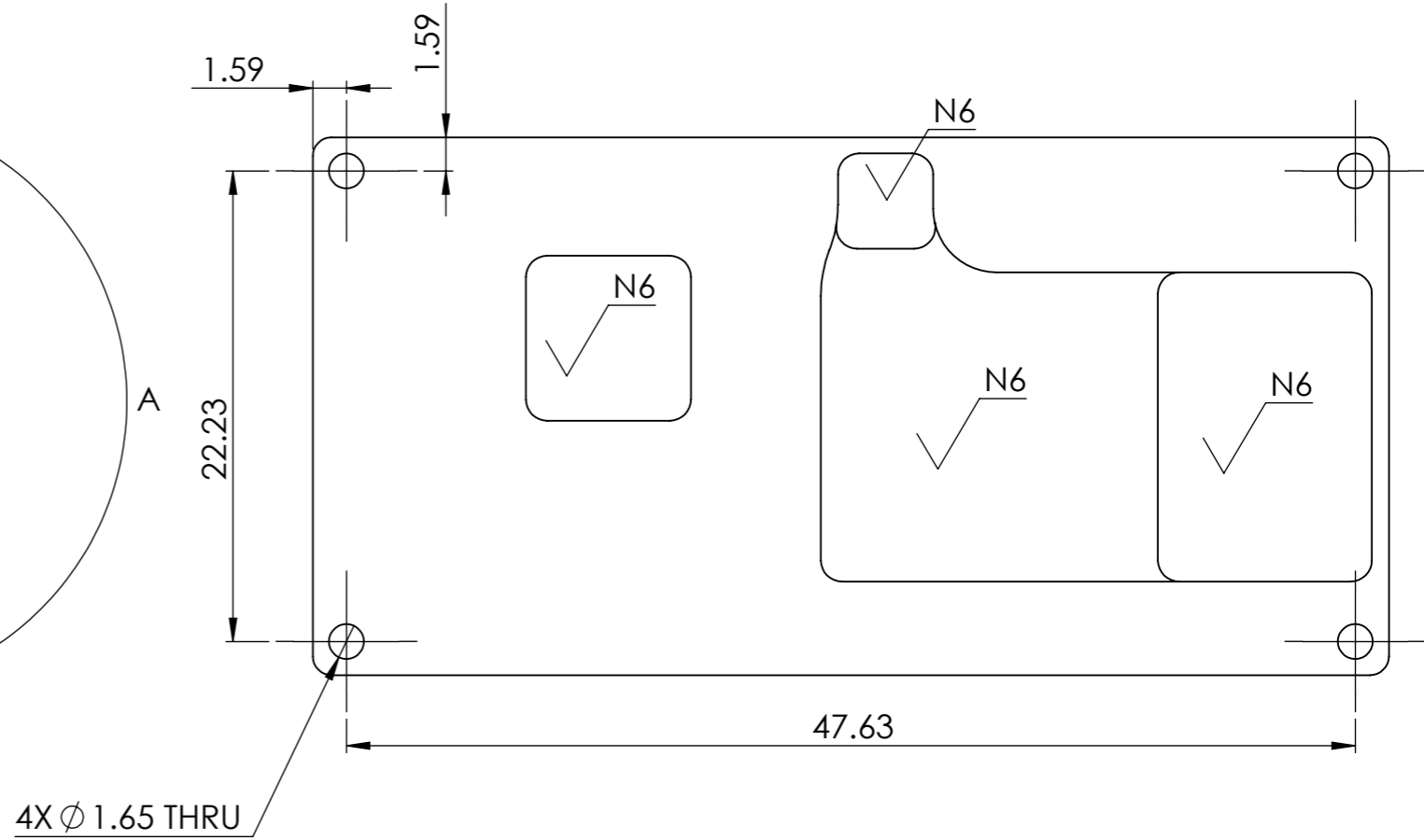
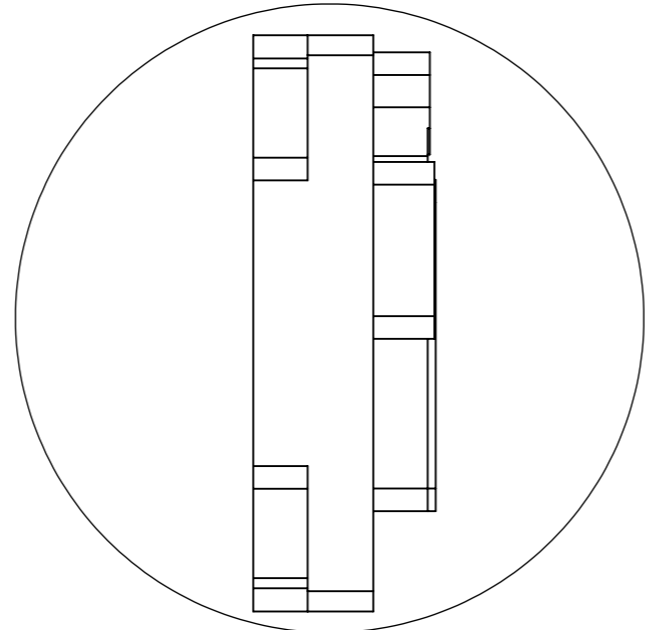
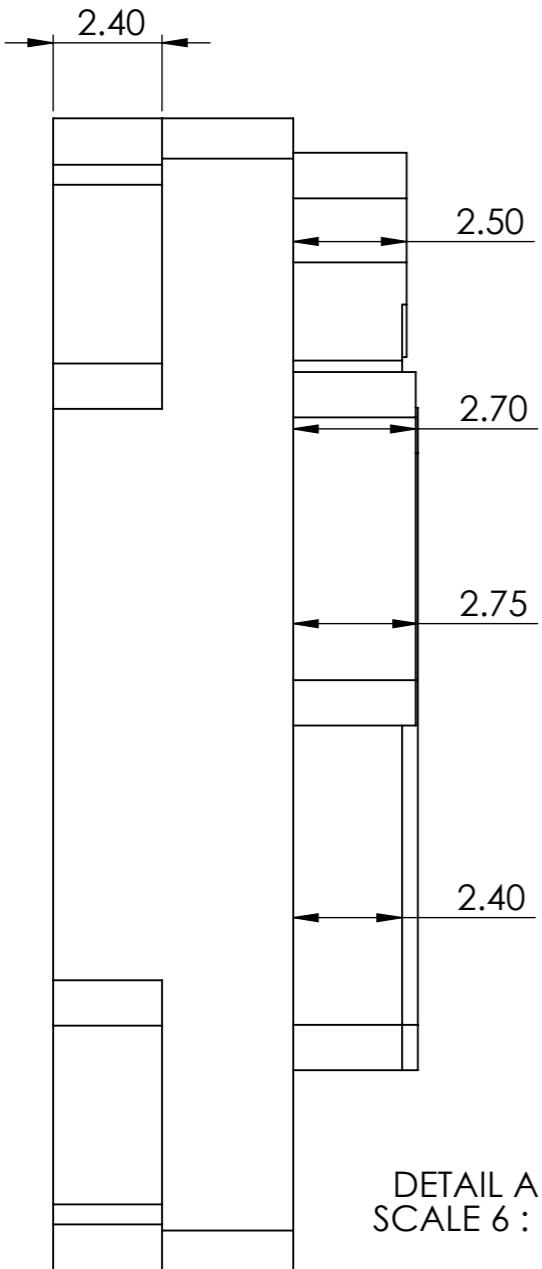

- NOTES:
1. MATERIAL: AL.ALLOY 6061-T6 PER AMS QQ-250/11 OR AMS QQ-A-225/B.
 2. The solid model file may be used for manufacturing and dimensional measurements purposes and shall be used for definition of dimensions not explicitly specified on the drawing. All notes and dimensional requirements specified on the drawing are obligatory.
 3. FINISH:
 A - Remove machining marks (Outside only)
 B - SPI D3 - Ra.190-230 made by #24 aluminum oxide sandblasting. OUTSIDE SURFACE ONLY
 4. COATING: Black Sulfuric Anodize per Mil-A-8625 Type II, Class 2
 5. All Faces **Marked BLUE** - 0.05 FLATNESS Tolerance.
 6. **MARKED RED** - LOGO LASER ENGRAVING
 7. Break all sharp edges R0.20 unless mentioned otherwise.
 8. All threads must be masked before plating/anodizing.

MATERIAL:		Aluminum 6061 T6													
FINISH:		See Notes													
UNLESS OTHERWISE SPECIFIED TOL. ARE: X.XX ±0.05 X.X ±0.1 X ±0.2	ROUGHNESS: See Notes														
	<table border="1"> <thead> <tr> <th></th> <th>NAME</th> <th>DATE</th> </tr> </thead> <tbody> <tr> <td>DRAWN</td> <td>Elad.K</td> <td>12/10/2022</td> </tr> <tr> <td>DESIGN</td> <td></td> <td>12/10/2022</td> </tr> <tr> <td>CHECK</td> <td></td> <td>30/04/2023</td> </tr> </tbody> </table>				NAME	DATE	DRAWN	Elad.K	12/10/2022	DESIGN		12/10/2022	CHECK		30/04/2023
		NAME	DATE												
DRAWN	Elad.K	12/10/2022													
DESIGN		12/10/2022													
CHECK		30/04/2023													
DIMENSIONS ARE IN mm FIRST ANGLE PROJECTION															

 6 Kompert Street P - +972-(0)77-4418391 Tel-Aviv, ISRAEL F - +972-(0)77-4418392 www.fit-r-d.com			
DESCRIPTION:		Sheet2	
DWG NO:		338_1001_V03	
REV		A	
A3	SHEET # 2	OUT OF 4	SCALE: 3:1

- This document is confidential.
 - All sole property of "FIT R&D".
 - Not to be copied or distributed.

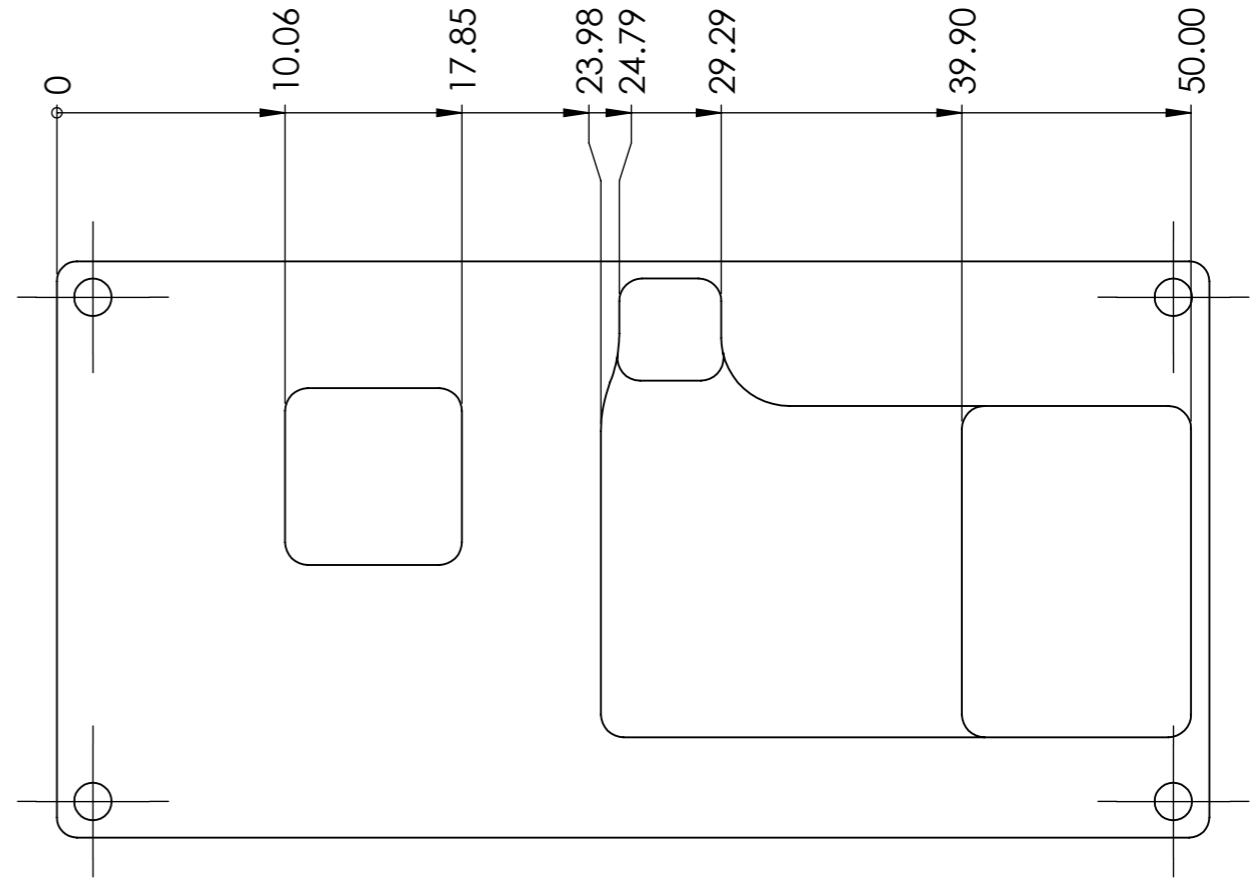
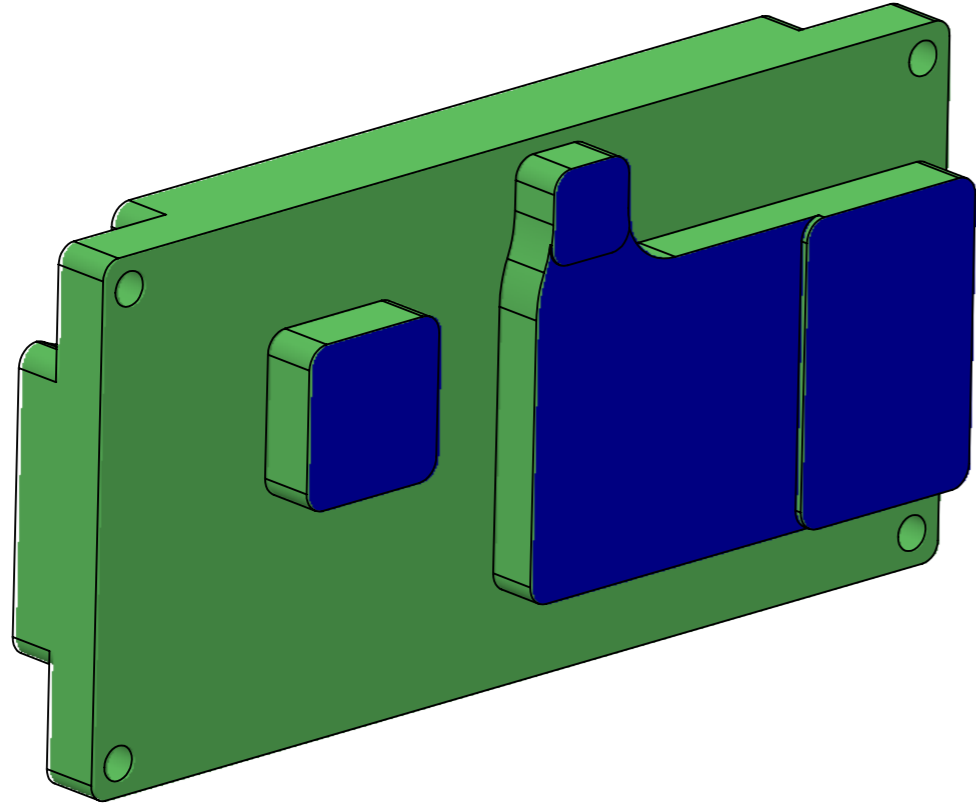

NOTES:

1. MATERIAL: AL.ALLOY 6061-T6 PER AMS QQ-250/11 OR AMS QQ-A-225/B.
2. The solid model file may be used for manufacturing and dimensional measurements purposes and shall be used for definition of dimensions not explicitly specified on the drawing. All notes and dimensional requirements specified on the drawing are obligatory.
3. FINISH:
 A - Remove machining marks (Outside only)
 B - SPI D3 - Ra.190-230 made by #24 aluminum oxide sandblasting. OUTSIDE SURFACE ONLY
4. COATING: Black Sulfuric Anodize per Mil-A-8625 Type II, Class 2
5. All Faces **Marked BLUE** - 0.05 FLATNESS Tolerance.
6. **MARKED RED** - LOGO LASER ENGRAVING
7. Break all sharp edges R0.20 unless mentioned otherwise.
8. All threads must be masked before plating/anodizing.

MATERIAL:		Aluminum 6061 T6		 6 Kompert Street P - +972-(0)77-4418391 Tel-Aviv, ISRAEL F - +972-(0)77-4418392 www.fit-r-d.com	
FINISH:		See Notes			
UNLESS OTHERWISE SPECIFIED TOL. ARE:		ROUGHNESS:		DESCRIPTION:	
X.XX	+0.05	See Notes		Sheet3	
X.X	+0.1			DWG NO:	
X	+0.2			338_1001_V03	
ANGLES ±0.5°		NAME	DATE	REV	
DIMENSIONS ARE IN mm		DRAWN	12/10/2022	A	
FIRST ANGLE PROJECTION		DESIGN	12/10/2022		
		CHECK	30/04/2023		
		A3		SHEET # 3 OUT OF 4 SCALE: 3:1	

- This document is confidential.
 - All sole property of "FIT R&D".
 - Not to be copied or distributed.

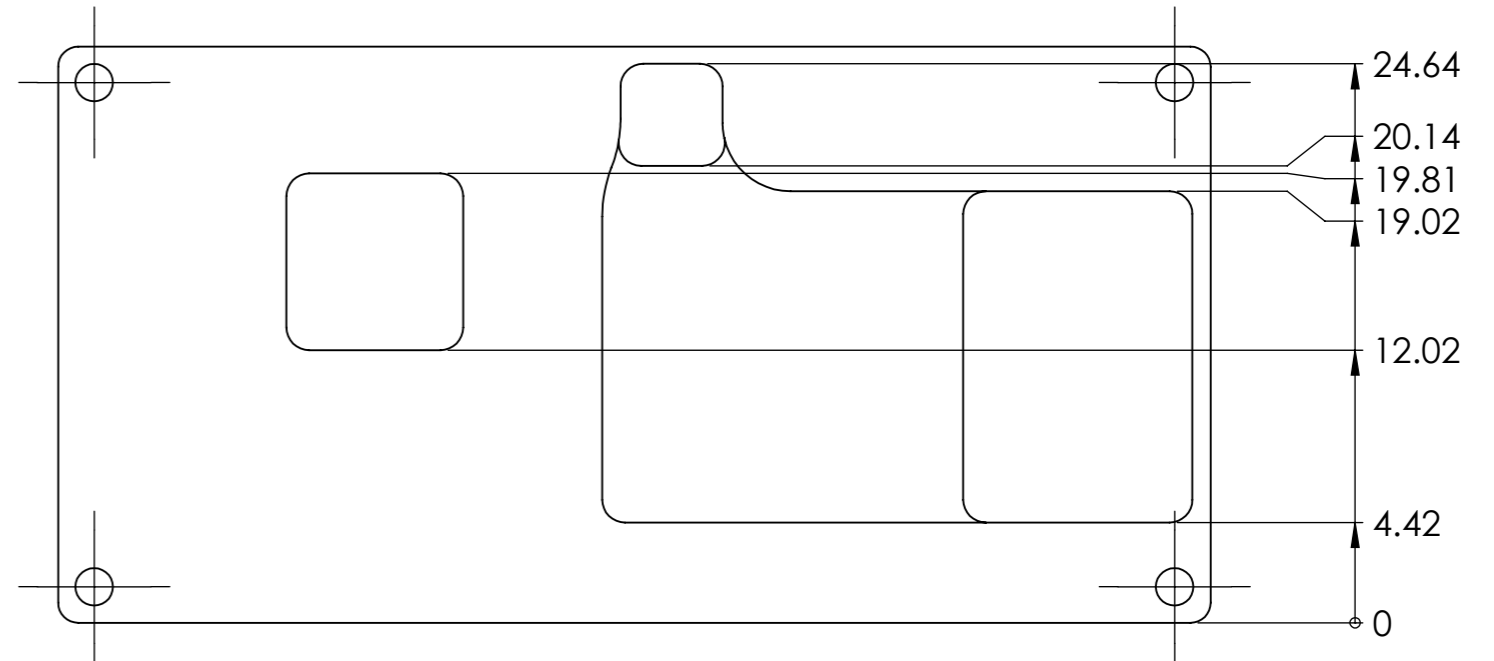
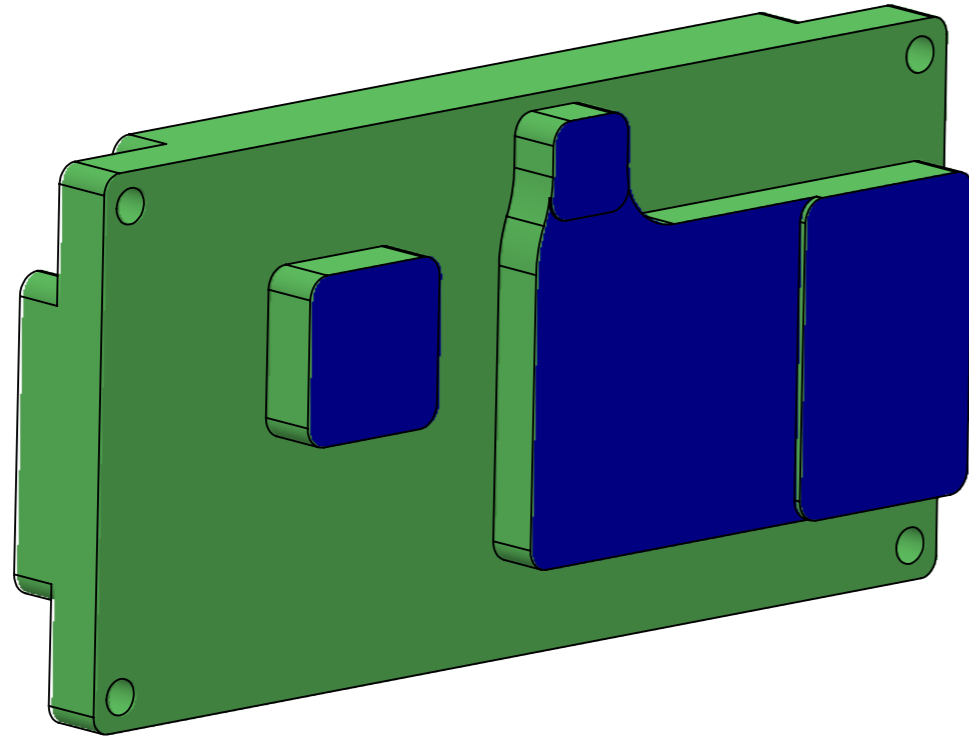

- NOTES:
- MATERIAL: AL.ALLOY 6061-T6 PER AMS QQ-250/11 OR AMS QQ-A-225/B.
 - The solid model file may be used for manufacturing and dimensional measurements purposes and shall be used for definition of dimensions not explicitly specified on the drawing. All notes and dimensional requirements specified on the drawing are obligatory.
 - FINISH:
 A - Remove machining marks (Outside only)
 B - SPI D3 - Ra.190-230 made by #24 aluminum oxide sandblasting. OUTSIDE SURFACE ONLY
 - COATING: Black Sulfuric Anodize per Mil-A-8625 Type II, Class 2
 - All Faces **Marked BLUE** - 0.05 FLATNESS Tolerance.
 - MARKED RED** - LOGO LASER ENGRAVING
 - Break all sharp edges R0.20 unless mentioned otherwise.
 - All threads must be masked before plating/anodizing.

MATERIAL:		Aluminum 6061 T6		 6 Kompert Street P - +972-(0)77-4418391 Tel-Aviv, ISRAEL F - +972-(0)77-4418392 www.fit-r-d.com	
FINISH:		See Notes		DESCRIPTION:	
UNLESS OTHERWISE SPECIFIED TOL. ARE:		ROUGHNESS:		Sheet4	
X.XX	+0.05	See Notes		DWG NO:	
X.X	+0.1			338_1001_V03	
X	+0.2			REV	
ANGLES ±0.5°				A	
DIMENSIONS ARE IN mm		DRAWN	Elad.K	12/10/2022	
FIRST ANGLE PROJECTION		DESIGN		12/10/2022	
		CHECK		30/04/2023	
		A3		SHEET # 4 OUT OF 4	
				SCALE: 3:1	